

Introduction and Problem Formulation

The primary goal of our design is to solve the existing problem of ineffective battery powering solutions. Currently the other products in this market partially solve this problem. The primary charger used is the AC adapter charger provided with the phone at the time of purchase. The next most popular is the car charger, which requires that the cell phone remain in the car during charging, but also that the car remain on. Other newer solutions in this market deal with temporarily satisfying powering problems. Products like the Cellboost® and the Sidewinder® are marketed to provide no more than an hours worth of talk time until the battery goes completely dead. There is not, however, a solution that manages to keep the battery charged continuously to avoid needing emergency charging solutions.

We have designed a cell phone battery regeneration system that converts kinetic energy into electrical energy to charge cell phone batteries. In addition to being able to convert energy sources, this device is also able to create this kinetic energy with the user's own movement. A magnetic pendulum inspired device is attached to the design to allow for the user to produce kinetic energy for the phone with simple movements such as walking. This device is also unique in its potential implementations. Although our current design deals primarily with the proper functioning of the circuit in general, there is potential for future implementation of this design directly into cell phone batteries as well as implementation of interchangeable charger interface connectors, allowing for the user to not have to repurchase the product for a new phone, but rather a new connector at a very reasonable price.

The cell phone battery regeneration system was created for the consumer to have a "hands-free" and hassle free battery charging solution. Through incidental and intentional body movements, the user is able to keep their phone charged. Many products fall short in their ability to provide a charging solution that either all cell phone users can easily access or that is affordable in the long run. Car chargers, solar batteries, and the Sidewinder® all require that the user have access to a vehicle, have direct lighting, and have their hands free when using the product, respectively. Even extended life batteries still lose their charge capacity over time, and the Cellboost® may become very costly over time. There is also no product out that does not require any active participation by the user and that can also boast being a cost effective long-term solution. The cell phone battery regeneration system eliminates the need for supplementing other ineffective powering solutions by providing the ultimate solution to inconvenient cell phone battery failure.

In order to work toward our design goals, we decided to break down the cell phone battery regeneration system into five parts, as seen in Figure 1.

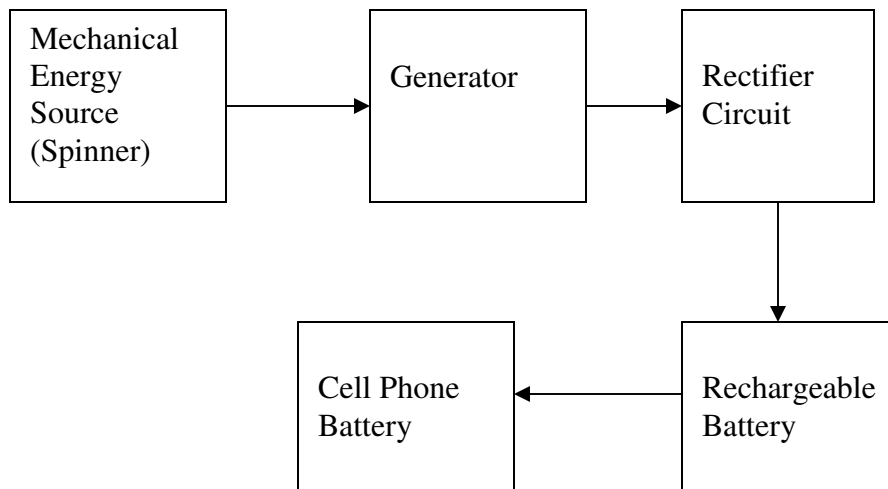

Figure 1: Block diagram of the cell phone battery regeneration system

The Mechanical Energy Source, or Spinner, is the mechanism to which we create the kinetic energy that ultimately powers the battery. The Generator converts the kinetic energy to electrical energy. The Rectifier circuit converts the electrical energy from AC to DC. The rechargeable battery is used to stabilize the voltage and current leaving the circuit and entering the cell phone. The cell phone itself is needed to show that this system actually works.

Design Analysis

In the Introduction and Problem formulation, we went through the block diagram that described the five major components of our design. In this section, we will provide an in depth analysis of each major component. This section explains technical specifications our design called for as well as the specific implementation needs.

Mechanical Energy Source

In designing a product like the cell phone regeneration system, we needed to make sure that the source of our mechanical energy fell within certain guidelines. We wanted the source of mechanical energy, referred to as the “spinner”, to continuously spin. This means that the user should not have to manipulate the spinner in anyway to ensure that it provides energy. The spinner must have a minimum amount of friction, allowing all energy dissipated to go into the generator. The spinner should also be relatively small and flat, given that this entire system should be able to fit at the back of a cell phone. Lastly, the device should cause no interference with any other components. One of our design options calls for a spinner that is made with magnets. This design should in no way interfere with any of the other components, especially the cell phone itself.

Our options for the spinner included a magnetic pendulum inspired design, a weighted disk design, and a windmill-like design called a shaker. Through a brief trial and error, we tested each of the designs by connecting them to a generator. Once connected to the generator, we would determine whether or not the spinner option was able to provide enough energy needed to power the circuit, and ultimately charge the cell phone battery. The first spinner design we tried was the shaker. From the beginning we had a hard time making a shaker due to the need for a component that was thin enough and was in the precise shape of a circle. We had a hard time acquiring anything that would fit this description so we decided to scrap the design all together.

The second design that we tried was the magnetic pendulum inspired design. This design called for small cylindrical magnets to be glued down in a circle, even spaced apart, with all off the north poles facing up. In the center of the circle, there will be another flat magnet with the center of the magnet attached to the generator. This design, theoretically, should have the north pole of the center magnet continuously moving away from all of the north poles of the circled magnets, while the south pole of the center magnet was being attracted toward them. This design was the best one, conceptually, but when we had to actually build it, we had many problems, including getting the magnets to space properly due to the magnetic attractions. The design was by far the hardest to put together, and thus our final product wasn't nearly what we expected it to be, so we scrapped it.

The weighted disc was the final spinner option that we tested. The theory behind this option is that one side of the disc would be weighted and any movement of the disc experiences would cause it to rotate in both directions. When attached to the generator, it produces positive and negative voltages, which the following circuit would rectify. To test out this concept, we used plastic discs, comparable in size to a compact disc, and added small weights to one side. We attached the center to a generator and rocked the disc back and forth to simulate a walking motion. We were very pleased with this experiment because we were able to get a nice constant amount of power from the generator and decided that this would be the spinner design for our system. For the actual implementation, we decided that we would shrink the size of the disc.

Generator

Being the crucial part of this project, a majority of time was dedicated to selecting a generator. After some thorough research, we selected about three generators to implement in our design with and test them accordingly with a basic diode rectifier circuit. When choosing a generator, we wanted to make sure that it would provide the greatest amount of power, be of relatively small size, and have a near frictionless axle. The first generator that we tried was a 9V generator that came with a hand crank kit that we purchased. This generator produced the values that the system required, but it was relatively large for our needs. It was also in need of better gearing so we decided to scrap it.

Our second design was a 4V generator. We wanted to use a smaller generator and see whether it could produce enough voltage that we may be able to boost with the rectifier